



## Lesson no. 8: InDesign Toolbox

### InDesign Tool Box and Function Working with Toolbox:-

**23 ROTATE TOOL (R) -** This tool is used to rotate objects and text boxes.. Click and drag clockwise to rotate the image until the head is approximately vertical (about  $-25^\circ$ ), and then release the mouse button. As you drag, the angle of rotation is displayed along with the image. You can rotate the content of a graphics frame with the Selection tool. 

You can also rotate a selected object by choosing Object > Transform > Rotate and entering a value in the Angle field of the Rotate dialog box.

In the Control panel, make sure that the center point in the reference point locator. () is selected.

Move the pointer slightly outside the resizing handle at the upper-right corner of the picture. The rotate pointer () is displayed.

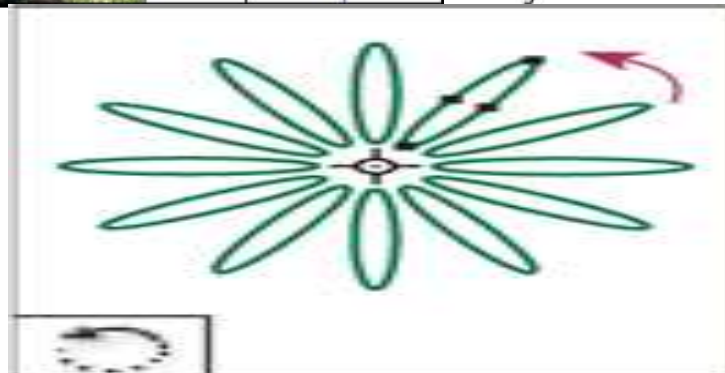
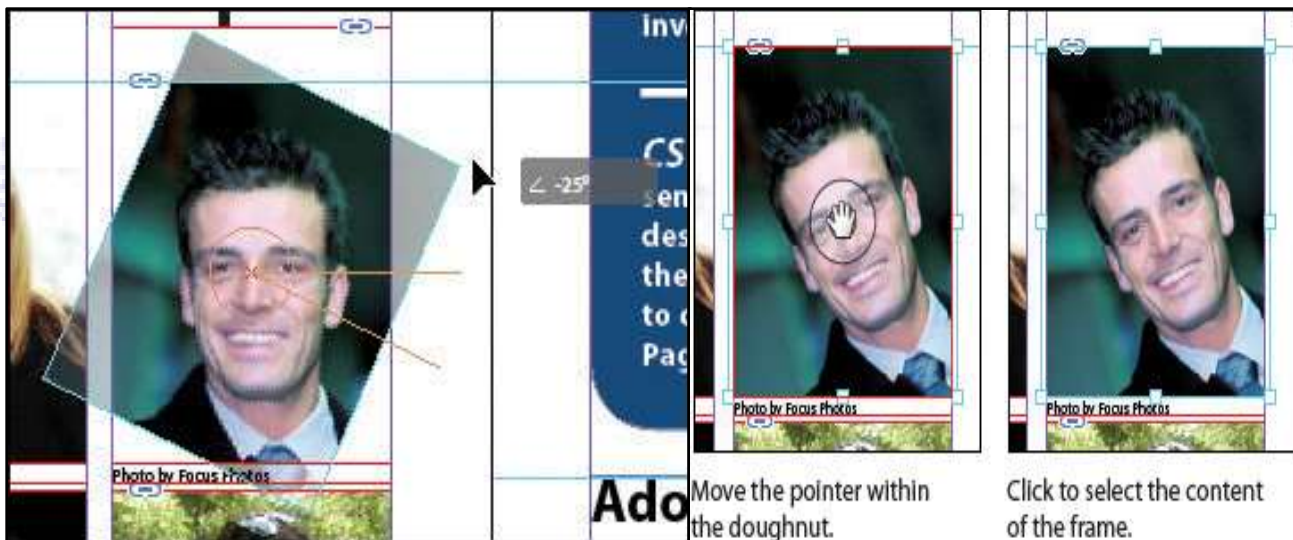

**Rotate tool lets you rotate objects around a fixed point.**

**24 SCALE TOOL (S)-** The Scale Tool allows you to scale an object or text box. Note, again, that the text inside a text box gets distorted unless you hold shift. To resize the picture and its frame with the Scale or Free Transform tools, just grab the frame handle and drag. To maintain the image proportions as you scale, you'll still need to hold down the **Shift key**—but you can press it at any time before or after you begin dragging. 

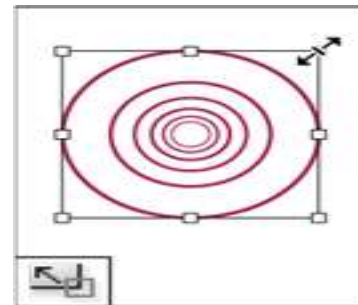
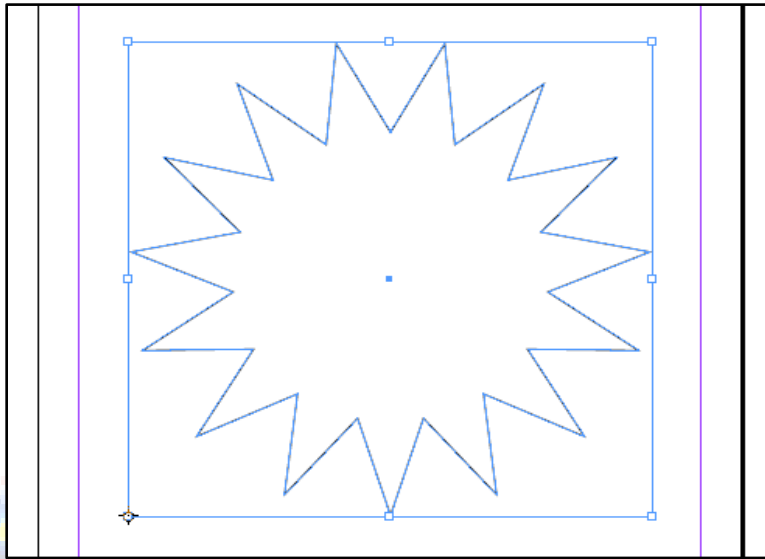

**Scale tool lets you resize objects around a fixed point.**

**25 SHEAR TOOL (O) -** The Shear Tool allows you to distort your object by making it a parallelogram. (My grade school geometry teacher would be so proud. 

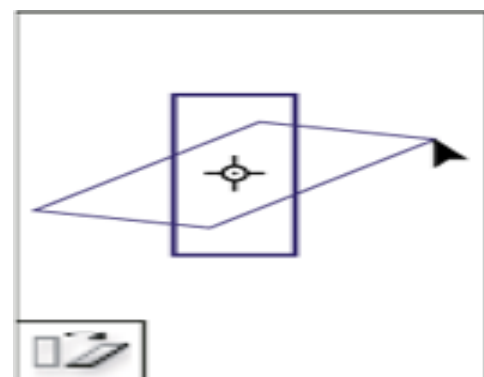
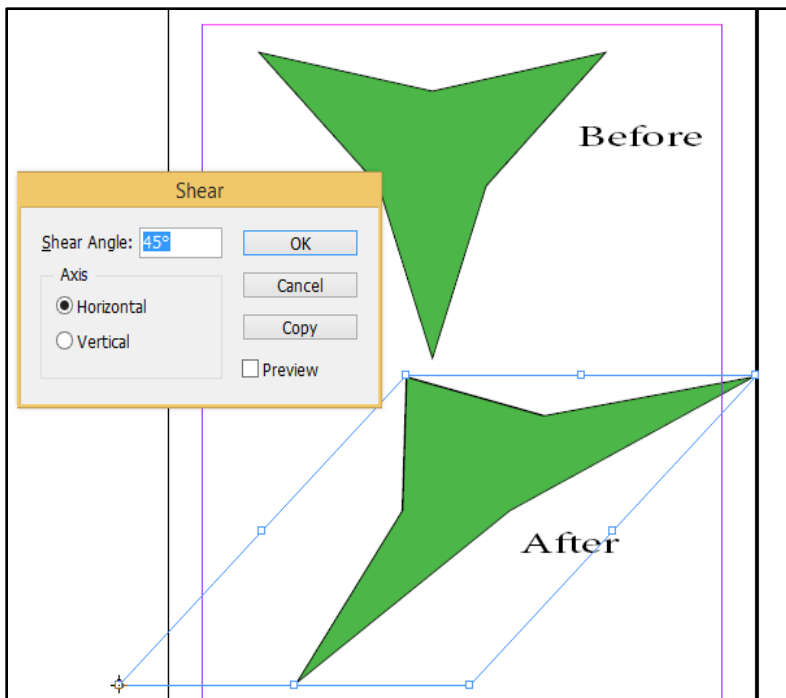

**Shear tool lets you skew objects around a fixed point.**

**26 GRADIENT SWATCH TOOL -** The Gradient Swatch Tool creates a gradient! Crazy, right? It makes it over the entire object you've selected. Simply drag from one spot to another to adjust how intense of a gradient it is. The longer the line, the more gradual the gradient becomes. The spot where you start is the one color, and the spot where you end is the other color. You can also change the colors, intensity, and direction in the Gradient Window on the right-hand side or in the Windows menu. To open the Gradient panel, choose Window > Color > Gradient, or double-click the Gradient tool in the Toolbox. To define the starting color of a gradient, click the leftmost color stop below the gradient bar, and then do one of the following: Drag a swatch from the Swatches panel and drop it on the color stop. 

To open the **Gradient panel**, choose Window > Color > **Gradient**, or double-click the **Gradient tool** in the Toolbox. To define the starting color of a gradient, click the leftmost color stop below the gradient bar, and then do one of the following: Drag a swatch from the Swatches panel and drop it on the color stop.

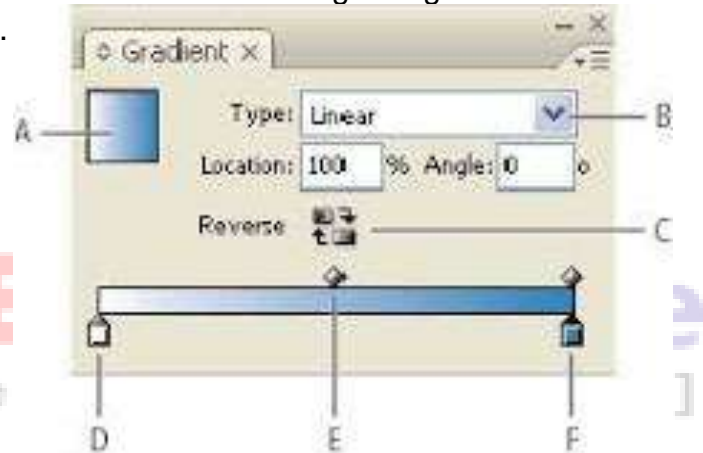

**Gradient Swatch tool lets you adjust the beginning and ending points and angle of gradients within objects.**